

PTR BALER & COMPACTOR

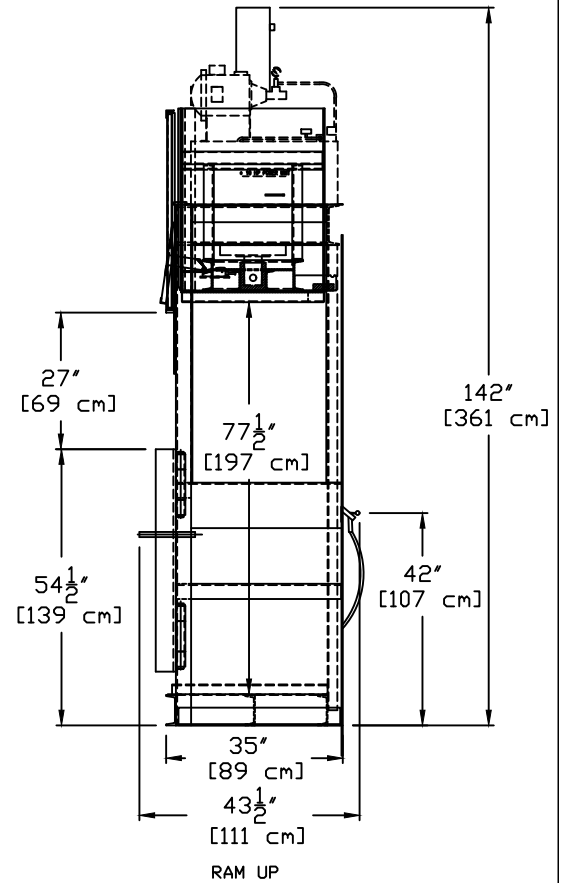
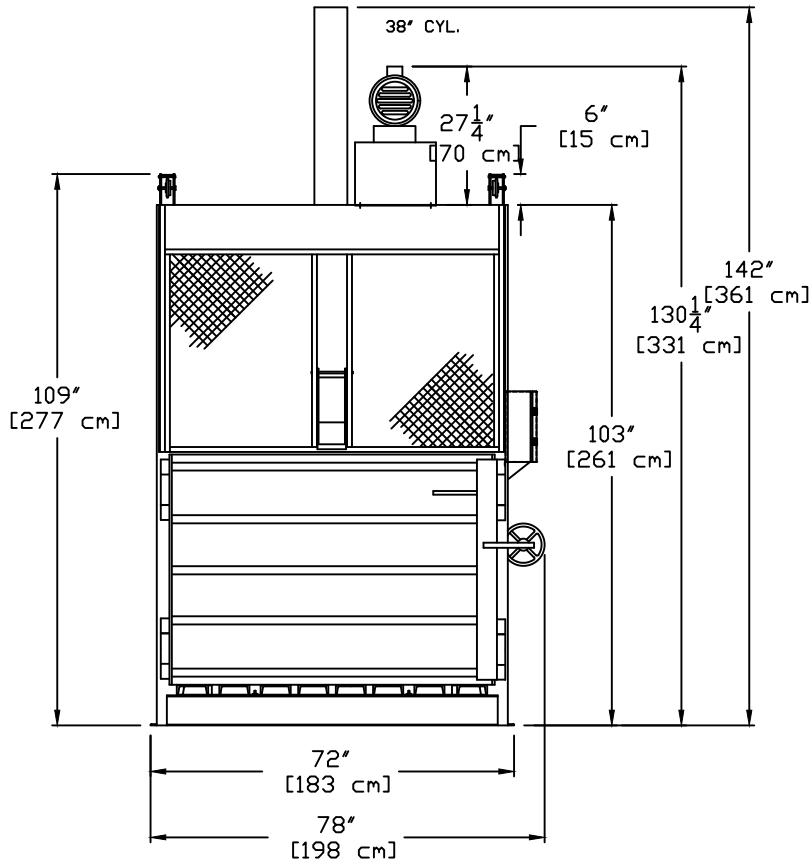

CONTROL BOX
SCALE = 2X

ALL DIMENSION AND SPECIFICATIONS ARE FOR REFERENCE ONLY, ACTUAL DIMENSIONS AND PERFORMANCE CHARACTERISTICS MAY VARY.

SPECIFICATIONS

BALE WEIGHT	750 - 900 LBS OCC	[340- 408 Kg]
BALE SIZE	60" WIDE X 30" DEEP X 48" TALL	[152 X 75 X 122 cm]
FEED OPENING	60" X 27"	[152 X 122 cm]
PLATEN FORCE		
WORKING	56,538 LBS	[251,494 N]
RELIEF	65,019 LBS	[289,219 N]
SYSTEM PRESSURE		
WORKING	2,000 PSI	[13,790 KPa]
RELIEF	2,300 PSI	[15,858 KPa]
RAM PRESSURE		
NOM	30.9 PSI	[213 KPa]
MAX	35.5 PSI	[245 KPa]
AVERAGE CYCLE TIME	56 SEC.	
CYLINDER BORE	6" [15.24 cm]	
CYLINDER STROKE	38" [97 cm]	
CYLINDER ROD	3 1/2" [8.9 cm]	
MOTOR	10 HP (208/230/460V-3 PHASE) [7.45 Kw]	
PUMP	10.5 GPM [39.75 L/m]	
SHIP WEIGHT	4,470 LBS [2,037 Kg]	

BP 2-1-17
SHT 2 OF 2

TITLE: 2300HDLP BALER SPECIFICATION

DWG. NOAB403395R3